

INSTALLATION INSTRUCTIONS

1. Use the existing mounting nuts and washers, or replace, as indicated by condition. Torque the nuts to tightening torque indicated in TCM Engine Overhaul Manual (typically 275-325 In. Lb.).
2. Remove the nut and internal-tooth lockwasher from the Power Lead bolt. Put the power cable terminal over the Power Lead bolt, followed by the internal-tooth lockwasher and the nut. Hold a backup on the lower nut and torque the top nut to 50 In. Lb. Do not over-torque. Place insulating nipple over terminal connection.
3. A Rotation Inspection Port is located over the clutch drum for the purpose of establishing whether the starter motor is turning the engines starter adapter. There are no field repairable components in this unit.

REVISIONS

LTR.	DESCRIPTION	DATE	APRV.
A	ADDED NOTE 3, CHANGE NOTE 2	12/17/03	EC
B	CORRECTED VIEW AND DIMENSIONS	10/30/08	EC
C	REVISED PMA LABEL, ADDED DATA CHART	08/14/09	RVC

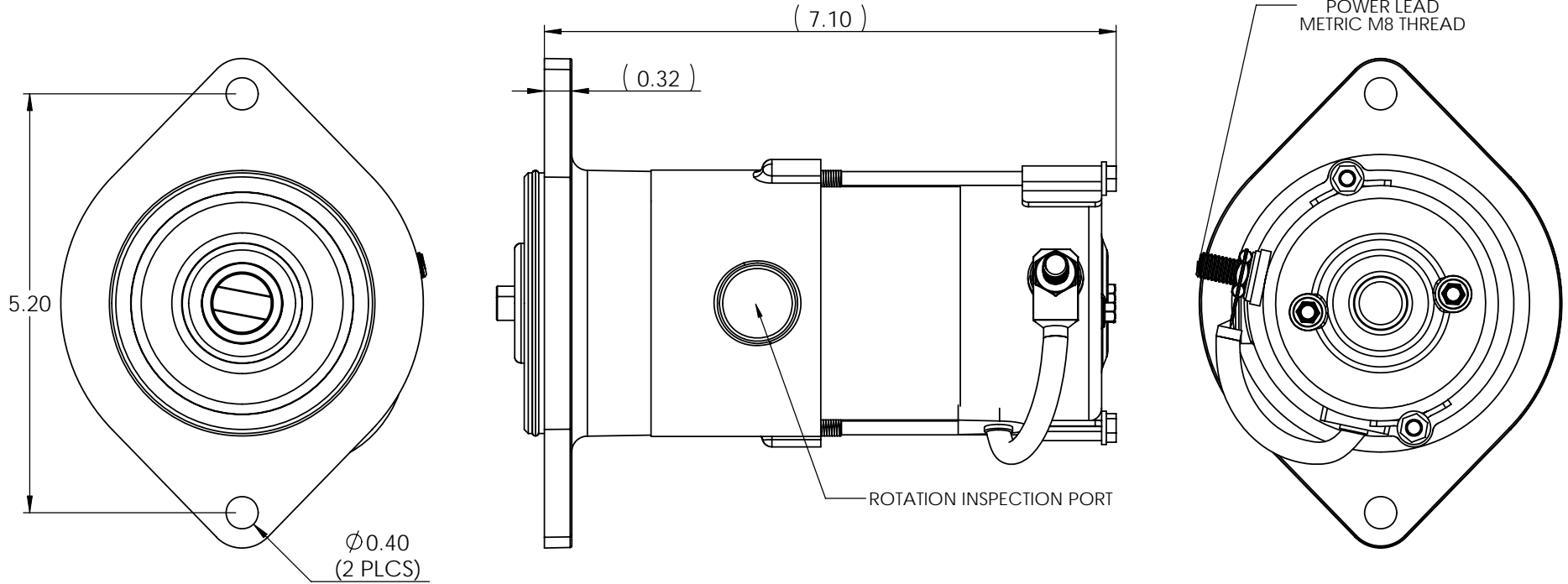

NOTE: DIMENSIONS IN PARENTHESIS ARE FOR REFERENCE ONLY

PMA LABEL DATA CHART

MODEL	S/N	PITCH	VOLTS
C12ST3	2C3-	N/A	12
C24ST3	4C3-	N/A	24

PMA LABEL

Sky-Tec FAA-PMA

For eligibility see PMA PQ0852SW Supplement No. [##] at www.skytecair.com/eligibility.htm

Model No.	Serial No.
[MODEL NO.]	[SERIAL NO.]
Rev [REV] Pitch [PITCH]	Volts [V/S]

Sky-Tec Partners, Ltd.

Granbury, Texas

C12ST3/C24ST3 INSTALLATION INSTR.

DRAWN BY: E. CHIAPPE	DATE: 09/02/03
MATERIAL:	DWG. NO. 30001 REV. C